

# AMS-5701

Theta Arm 5G Antenna Measurement System (3D)

---



## **User Manual**

PN: 1748531

May, 2022

Rev B

ETS-Lindgren Inc. reserves the right to make changes to any products herein to improve functioning or design. Although the information in this document has been carefully reviewed and is believed to be reliable, ETS-Lindgren does not assume any liability arising out of the application or use of any product or circuit described herein; nor does it convey any license under its patent rights nor the rights of others. All trademarks are the property of their respective owners.

**© Copyright 2022 written permission from ETS-Lindgren Inc. All Rights Reserved. No part of this document may be copied by any means without written permission from ETS-Lindgren Inc.**

Trademarks used in this document: The ETS-Lindgren logo and EMQuest are trademarks of ETS-Lindgren Inc. Windows is the trademark of the Microsoft Corporation.

### Revision Record

MANUAL, AMS- 5701 | Part # 1748531 Rev B

Revision	Description	Date
A	Initial Release	April, 2022
B	Corrected intro; axis information	May, 2022

# TABLE OF CONTENTS



---

- NOTES, CAUTIONS AND WARNINGS . . . . . 5
- SAFETY INFORMATION . . . . . 6
- INTRODUCTION. . . . . 7
  - Standard Configuration . . . . . 8
  - ETS-Lindgren Product Information Bulletin . . . . . 8
- MAINTENANCE . . . . . 9
  - Routine Maintenance . . . . . 9
  - Foam Gasket Maintenance . . . . . 9
    - Foam Gasket Removal . . . . . 9
    - Foam Gasket Installation . . . . . 10
  - Air Vents. . . . . 10
  - Safety Precautions . . . . . 10
  - Service Procedures. . . . . 11
  - Replacement Parts. . . . . 11
- SPECIFICATIONS . . . . . 12
  - Physical Specifications . . . . . 12
  - Electrical Specifications . . . . . 12
- INSTALLATION . . . . . 13
  - Locating the AMS-5701 . . . . . 13
  - Installation. . . . . 13
    - RF-Shielded Hatch . . . . . 13
- MOUNTING . . . . . 14
  - Adjusting the Height of the Positioner . . . . . 14
  - Input / Output Connections . . . . . 15
    - Trigger . . . . . 15
    - Reset . . . . . 15
    - Fiber Optic. . . . . 15
- OPERATION . . . . . 16
  - AMS-5701 Command Set . . . . . 17
    - General Command Structure . . . . . 17
    - System Commands . . . . . 18
    - Control Commands. . . . . 19
    - Error Codes . . . . . 24
- NETWORK CONFIGURATION . . . . . 25
  - Network Factory Configuration . . . . . 25
  - Changing the Positioner IP Address. . . . . 25

Reset to Factory Default . . . . .	.27
Computer Network Configuration . . . . .	.27
Background Information . . . . .	.28
Multiple Devices in a LAN. . . . .	.32

## NOTES, CAUTIONS AND WARNINGS













---

	<b>Note:</b> Denotes helpful information intended to provide tips for better use of the product.
	<b>CAUTION:</b> Denotes a hazard. Failure to follow instructions could result in minor personal injury and/or property damage. Included text gives proper procedures.
	<b>WARNING:</b> Denotes a hazard. Failure to follow instructions could result in <b>SEVERE</b> personal injury and/or property damage. Included text gives proper procedures.



See the ETS-Lindgren *Product Information Bulletin* for safety, regulatory, and other product marking information

# SAFETY INFORMATION

	<p>See the ETS-Lindgren <i>Product Information Bulletin</i> for safety, regulatory, and other product marking information.</p>
	<p><b>Refer to Manual:</b> When product is marked with this symbol, see the instruction manual for additional information. Manuals are available for download at <a href="http://ets-lindgren.com">ets-lindgren.com</a>, or contact ETS-Lindgren Technical Support.</p>
	<p><b>High Voltage:</b> Indicates presence of hazardous voltage. Unsafe practice could result in severe personal injury or death.</p>
	<p><b>Only qualified personnel</b> should operate (or service) this equipment. The electrical installation of this product should be accomplished by an individual who is authorized to do so by the appropriate local authority. The installation should be in compliance with local electrical safety codes.</p>
	<p><b>Heavy Object:</b> Unassisted lifting can cause injury. Mechanical assistance is required.</p>
	<p><b>Stay clear</b> of moving components during operation of equipment. Moving and/or falling equipment can cause serious injury.</p>
	<p><b>NEVER ROCK OR TILT:</b> Tipping or rocking may cause serious injury or death.</p>
	<p><b>Keep hands clear:</b> Moving parts can crush and cut.  <b>Pinch Points:</b> Keep hands clear during operation.</p>
	<p><b>Laser Warning:</b> Denotes a laser is part of the operating system of the device. Do not stare into beam or view directly with optical instruments.</p>
	<p><b>Do not fully enter chamber.</b> Check chamber prior to closing door. It is not an inhabitable space.</p>
	<p><b>Do not make any modifications to this unit without consulting the factory directly.</b>  <b>Before servicing:</b> Contact ETS-Lindgren. Servicing (or modifying) the unit by yourself may void your warranty. If you attempt to service the unit by yourself, disconnect all electrical power before starting. There are voltages at many points in the instrument which could, if contacted, cause personal injury. Only trained service personnel should perform adjustments and/or service procedures upon this instrument. Capacitors inside this instrument may still be charged even when instrument is disconnected from its power source.</p>
	<p><b>Protective Earth Ground (Safety Ground):</b> Indicates protective earth terminal. You should provide uninterruptible safety earth ground from the main power source to the product input wiring terminals, power cord, or supplied power cord set.</p> <p>Before power is applied to this instrument, ground it properly through the protective conductor of the AC power cable to a power source provided with the protective earth contact. Any interruption of the protective (grounding) conductor, inside or outside the instrument, or disconnection of the protective earth terminal could result in personal injury.</p>



ETS-Lindgren may substitute a similar part or new part number with the same functionality for another part/part number. Contact ETS-Lindgren for any questions about part numbers and ordering parts.



This assembly contains a laser. Do not stare into beam or view directly with optical instruments.

### WARNING



**High Voltage:**  
Unsafe practice could result in severe personal injury or death.

### WARNING



**Heavy Object:**  
Unassisted lifting can cause injury. Mechanical assistance is required.

## INTRODUCTION

The ETS-Lindgren AMS-5701 5G Antenna Measurement System is a distributed-axis far field system that provides 3-dimensional radiated performance measurements of mmWave wireless devices over the frequency range of 6 to 67 GHz. It incorporates a theta arm for phi axis and high precision turntable for theta movements of the antenna under test. AMS-5701 is optimized for testing smaller antenna arrays found on mobile, user premise, or module designs. Array sizes up to 6.8 cm at 24 GHz and 5.0 cm at 44 GHz can be fully characterized. The AMS-5701 also supports antennas with or without antenna feed ports.

This RF-shielded anechoic enclosure is mobile (on wheels) and is shareable and suitable for small spaces. The AMS-5701 also utilizes ETS-Lindgren's EMQuest™ EMQ-100 Antenna Measurement Software as its data acquisition and analysis package.

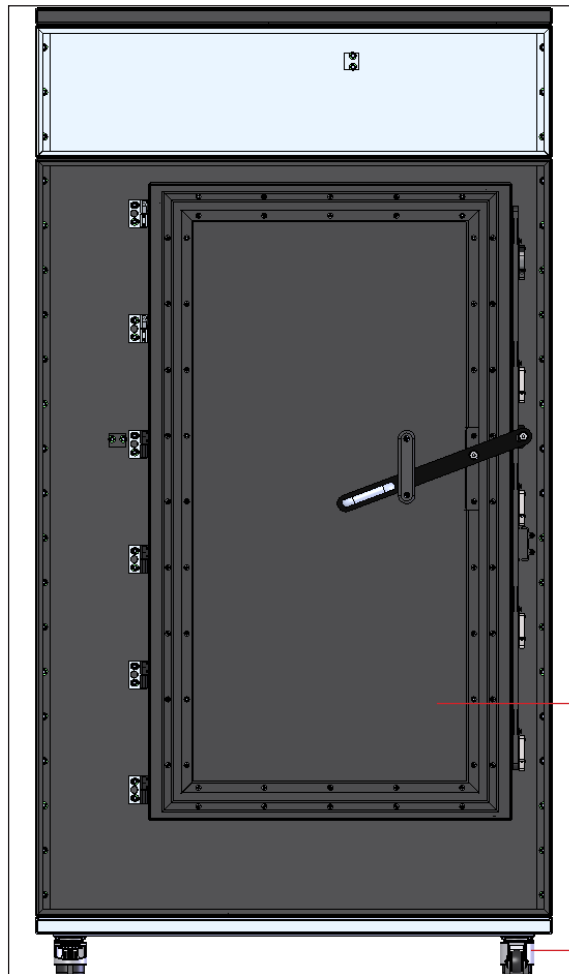

RF Hatch

Locking Casters

## WARNING

Before assembling, installing, or connecting any components, follow the safety information in the ETS-Lindgren *Product Information Bulletin* included with your shipment.



ETS-Lindgren may substitute a similar part or new part number with the same functionality for another part/part number. Contact ETS-Lindgren for any questions about part numbers and ordering parts.



This assembly contains a laser. Do not stare into beam or view directly with optical instruments.

## WARNING



### High Voltage:

Unsafe practice could result in severe personal injury or death.

## Standard Configuration

- Alignment Lasers
- Cables
- Dual Polarized Antenna on Theta Arm
- EMQuest Software
- Fixed 75 cm (29.5 in) Range Length
- Laser Alignment
- DUT Single Axis Phi Positioner
- Table Mount
- Phone Adapter Mount
- Power, RF, USB Slip Ring in the Phi Positioner

## ETS-Lindgren Product Information Bulletin

See the ETS-Lindgren *Product Information Bulletin* included with your shipment for the following:

- Safety, regulatory, and other product marking information
- Steps to receive your shipment
- Steps to return a component for service
- ETS-Lindgren calibration service
- ETS-Lindgren contact information



## WARNING

Before assembling, installing, or connecting any components, follow the safety information in the ETS-Lindgren *Product Information Bulletin* included with your shipment.



Only qualified personnel should operate (or service) this equipment. If you have any questions concerning maintenance, contact ETS-Lindgren Technical Support. Warranty may be voided if equipment is damaged by improperly performed maintenance.



Maintenance of the AMS-5701 is limited to external components described in the following sections. If you have questions concerning this or any other maintenance, contact ETS-Lindgren Technical Support.



The AMS-5701 must be protected against humidity, water, dirt or condense water.

## MAINTENANCE

The AMS-5701 is a three-part assembly, made so that it can fit through a 36" door opening when disassembled.

### Routine Maintenance

Before performing any maintenance, follow the safety information in the ETS-Lindgren *Product Information Bulletin* included with your shipment. Maintenance is limited to the components as described in this manual. If you have any questions concerning maintenance, contact ETS-Lindgren Technical Support.

- **Perform routine visual inspections.** Inspect before operating. Do not operate the AMS-5701 if there is any damage to the chamber, any peripheral equipment, or cabling.
- **Check absorber for damage.** Contact ETS-Lindgren to replace any damaged absorber
- **Check for excessive rotation.** Attempt to rotate the turntable top and arm by hand. Excessive rotation may indicate a loose drive component.
- **Listen for excessive noise.** Listen for excessive or unusual noise during turntable operation. Perform maintenance if necessary or call ETS-Lindgren Technical Support.
- **Check cables for wear.** Ensure they are clear of potential damage from moving parts.

### Foam Gasket Maintenance

- **Inspect the foam gaskets at the RF hatch** to make sure they are recessed in the groove located at the back of the channel. If a gasket is not recessed, replace it with new foam gasket (part# 1622208).
- **Order replacement gasket** (part# 1622208) from ETS-Lindgren.

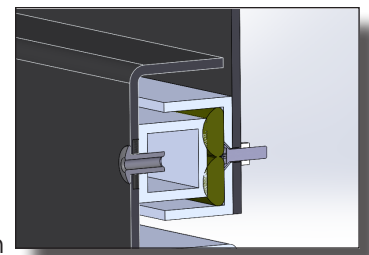

Foam Gasket at RF Hatch

### Foam Gasket Removal

1. Grab one end with needle-nose pliers and gently pull the gasket out from the groove. There is adhesive on the side of the gasket facing the groove.
2. Gently peel off the foam gaskets starting at one end.
3. Clean all remaining adhesive residue with rubbing alcohol.



Only qualified personnel should operate (or service) this equipment. If you have any questions concerning maintenance, contact ETS-Lindgren Technical Support. .

### WARNING



Moving and/or falling equipment can cause serious injury.

### WARNING



Electrical installation must be performed by a qualified electrician, and in accordance with local and national electrical standards.



This assembly contains a laser. Do not stare into beam or view directly with optical instruments.



#### Never rock or tilt:

Use caution not to tip the equipment when moving sections.

## Foam Gasket Installation

1. Cut new replacement Foam Door Gasket (1622208) to size, if needed.
2. Prepare mating surface by cleaning with rubbing alcohol.
3. Peel protective backer off the foam door gasket's adhesive side and apply it to the door's inner channel.
4. Place the gasket into the groove with the adhesive side facing the groove. Do not twist the gasket and do not place the gasket to the side of the groove.
5. Ensure the corner intersections have no visible gaps between the gasket sections. The top outer row must extend to both corners to meet and support the outer top rows. The outer bottom row should extend to meet the outer side rows in the bottom corner.



Gasket Padded Top

Gasket Adhesive Back

## Air Vents

The air vents on the AMS-5701 must be checked to make sure that free airflow exists to ensure optimum cooling. A small soft brush or low pressure air may be used to clean the honeycomb.

## Safety Precautions

- Electrical installation should be accomplished by individuals authorized by the appropriate local authority and the installation must be completed in compliance with local electrical safety codes.
- Never rock or tilt. Use caution when moving individual sections to prevent them from tipping.
- Do not perform maintenance while the equipment is operating.
- Moving parts can crush and cut. Keep hands clear.
- Falling equipment can cause injury and damage to equipment. Use caution.
- Do not attempt to step inside or crawl inside the chamber. It is not an inhabitable space.
- Do not stare into laser beams or view directly with optical instruments.
- The laser and light switch are on the interior wall to the left of the RF shielded hatch. Make sure they are off when the system is not in use.

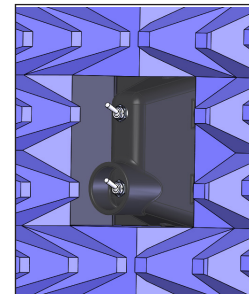

Laser Switch



Only qualified personnel should operate (or service) this equipment. If you have any questions concerning maintenance, contact ETS-Lindgren Technical Support.



ETS-Lindgren may substitute a similar part or new part number with the same functionality for another part/part number. Contact ETS-Lindgren for any questions about part numbers and ordering parts.



**Never rock or tilt:**

Use caution not to tip the equipment when moving sections.



**Heavy Object:**

Unassisted lifting can cause injury. Mechanical assistance is required.

## Service Procedures

For the steps to return a system or system component to ETS-Lindgren for service, see the *Product Information Bulletin* included with your shipment or contact ETS-Lindgren Technical Support.

## Replacement Parts

For replacement parts, contact ETS-Lindgren Technical Support.

Part Description	Part Number
AMS-5701 RF Cable Kit	1748827
Absorber Kit	1747821
Antenna	1745886
Block - Zero Set	1747321
Hardware Kit	1747767

# SPECIFICATIONS



ETS-Lindgren may substitute a similar part or new part number with the same functionality for another part/part number. Contact ETS-Lindgren for any questions about part numbers and ordering parts.

## WARNING



**Heavy Object:**  
Unassisted lifting can cause injury. Mechanical assistance is required.



**Never rock or tilt:**  
Use caution not to tip the equipment when moving sections.

## WARNING



Electrical installation must be performed by a qualified electrician, and in accordance with local and national electrical standards.

## Physical Specifications

<b>Typical Exterior Dimensions (Nominal):</b>	2.2 m x 1.7 m x 1.5 m (86.63 in x 46.14 x 58.62 in)
<b>Weight:</b>	192.32 kg (424 lbs)
<b>Max DUT Weight:</b>	5.0 kg (11.0 lb)

## Electrical Specifications

<b>Voltage (VAC), Theta Arm Drive System:</b>	208/240; IEC 320 C14
<b>Voltage (VAC), DUT Positioner Drive System:</b>	208/240; IEC 320 C14
<b>Equipment/DUT:</b>	115/230; IEC 320 C14
<b>Hertz (Hz):</b>	50/60 Hz
<b>Current (A) Drive System:</b>	20 A
<b>Current (A) Equipment/DUT:</b>	5 A

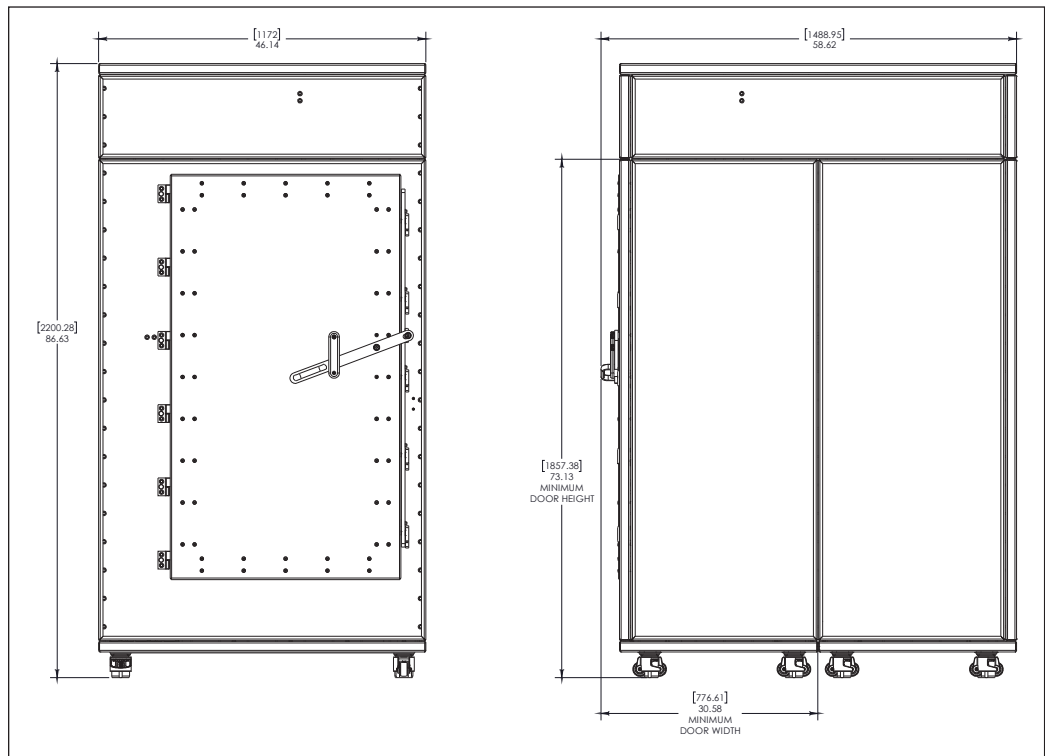

Overall Dimensions

# INSTALLATION



Only qualified personnel should operate (or service) this equipment. If you have any questions concerning maintenance, contact ETS-Lindgren Technical Support. .

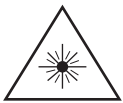

This assembly contains a laser. Do not stare into beam or view directly with optical instruments.



**Heavy Object:**  
Unassisted lifting can cause injury. Mechanical assistance is required.



**Never rock or tilt:**  
Use caution not to tip the equipment when moving sections.



Remember to release the caster brake before attempting to move the system.

## Locating the AMS-5701

Before moving the AMS-5701, verify that the dimensions of the hallway and doorway meet those outlined in the physical dimensions section in Specifications. If the dimensions are acceptable, ensure the hatch is closed and power has been removed from the system. Release the leveling feet of the casters and relocate the system.

If the dimensions of the hallway and doorway do not meet those illustrated, the system will need to be disassembled. Contact ETS-Lindgren Technical Support for instructions regarding disassembly and relocation. The AMS-5701 is designed to be divided into three sections for relocation purposes. If the system is disassembled and reassembled, the gaskets will need to be inspected.

## Installation

ETS-Lindgren provides installation of the AMS-5701. Ensure that there is clearance for the assembly and that the leveling casters are secured before operating.

### RF-Shielded Hatch

Close the hatch carefully to ensure that the locking mechanism is engaged at all points; excessive force is not required. Do not attempt to move or operate the system if the hatch does not close properly.

### Leveling Casters

Once the AMS-5701 has been moved to the intended location, ensure the casters are in the level position prior to configuring or operating the AMS-5701. To level the casters, spin the thumb wheel to adjust the leveling pad. One direction goes up and the other goes down.

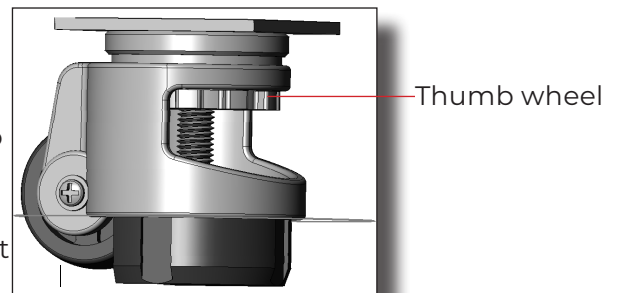

Leveling Caster



Only qualified personnel should operate (or service) this equipment. If you have any questions concerning maintenance, contact ETS-Lindgren Technical Support. .

**WARNING**



Electrical installation must be performed by a qualified electrician, and in accordance with local and national electrical standards.

**WARNING**



Moving and/or falling equipment can cause serious injury.



**Keep hands clear:**  
Moving parts can crush and cut.



**Pinch Points:**  
Keep hands clear during operation.

## MOUNTING

### Securing the DUT on the Positioner

The DUT is mounted to the Phi axis using M6 screws or the optional phone mount. The max load capacity is 11 lbs (5 kg).

1. Thread M6 screws through the openings. (Straps, hook and loop, etc. may be used to secure DUT.)
2. If cables are needed for DUT communication (in addition to the provided RF, DC, and USB cables through the slip ring) route the additional cables through the external cable clip on the back of the positioner. Limit rotation to prevent damage to cabling. The configuration of DUT cables is dependent upon specific test situations.

### Adjusting the Height of the Positioner

The height of the Phi axis positioner is adjustable.

1. Use the knob to loosen the upper column from the lower column.
2. Adjust the height of the positioner.
3. Use the knob to re-stabilize the upper column. Ensure that the knob is secure.

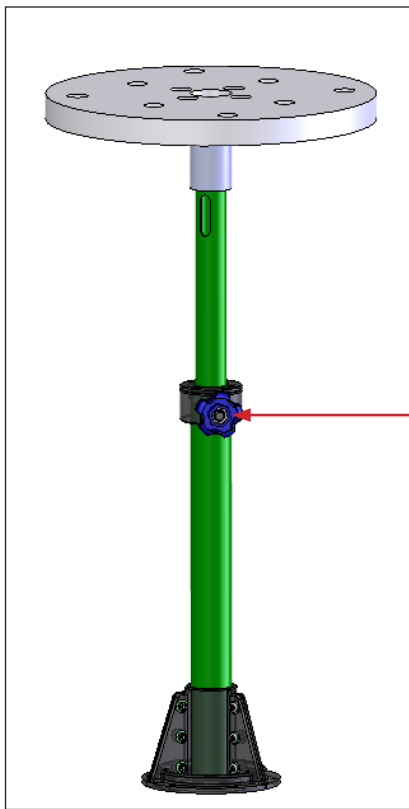

Height Adjustment Knob

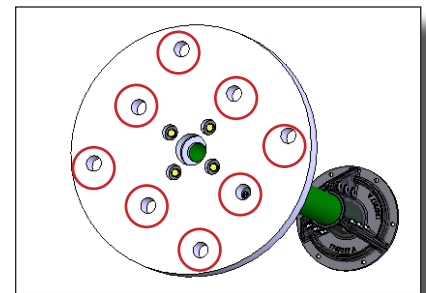

Mounting Holes

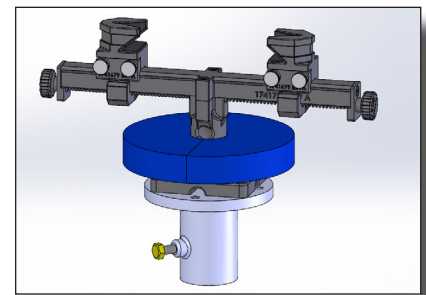

Phone Mount

## WARNING



### High Voltage:

Unsafe practice could result in severe personal injury or death.



Stay clear of all moving components.



### Keep hands clear:

Moving parts can crush and cut.



### Pinch Points:

Keep hands clear during operation.



### Moving Gears:

Do not stick hand in or near machine during operation.

## CAUTION

### Damaged or crimped AC cords:

Using damaged or crimped AC cords may damage the equipment and/or cause physical injury.

## Input / Output Connections

### Trigger

The positioner is equipped with a TTL-compatible output. This output is capable of driving a 50 ohm load that can be used to trigger a measurement sweep on a network analyzer (or other measurement device equipped with a TTL-compatible external trigger input option).

### Reset

Pressing Reset for more than 6 seconds resets the device IP address and mask to factory default, 192.168.0.100, 255.255.255.0. (Used in case the IP address of the device is unknown.)

### Fiber Optic

The positioner is equipped with a fiber-optic inlet and a fiber-optic outlet. Connect the positioner to the included Ethernet-to-fiber optic converter using the included dual fiber optic cable with type ST connections. The converter connects to the host computer via the included 0.9 m (3.0 ft) Cat5 Ethernet cable. Ensure the fiber converter TX line is connected to the positioner RX input connector, and the fiber converter RX line is connected to the positioner TX output connector.

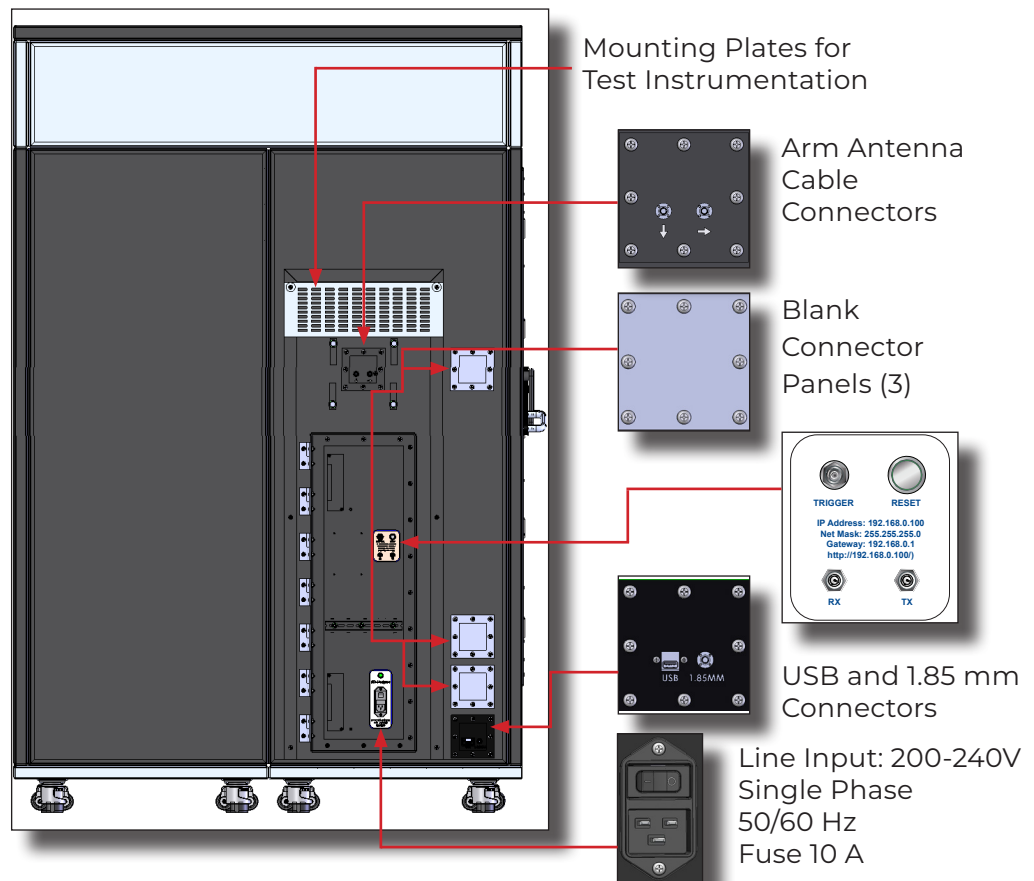

## OPERATION

Firmware is installed in the positioner, and it is controlled by PC.

### WARNING



#### High Voltage:

Unsafe practice could result in severe personal injury or death.



Stay clear of all moving components.



#### Never rock or tilt:

Use caution not to tip the equipment when moving sections.

### WARNING



Moving and/or falling equipment can cause serious injury.



Only qualified personnel should operate (or service) this equipment. If you have any questions concerning maintenance, contact ETS-Lindgren Technical Support.

### CAUTION

Read this manual completely before operating. Before and during operation, follow the safety information in the ETS-Lindgren *Product Information Bulletin* included with your shipment.

### WARNING

Ensure the current travel limit settings will not cause damage to existing cables.

### WARNING

Do not operate the AMS-5701 positioners in a stalled condition. Doing so can cause damage to the drive unit and will void the warranty. Ensure the positioner will continue to rotate under load at all speeds.



No homing procedure is necessary. Because they use static encoders, the axes will know their positions even after a power cycle.

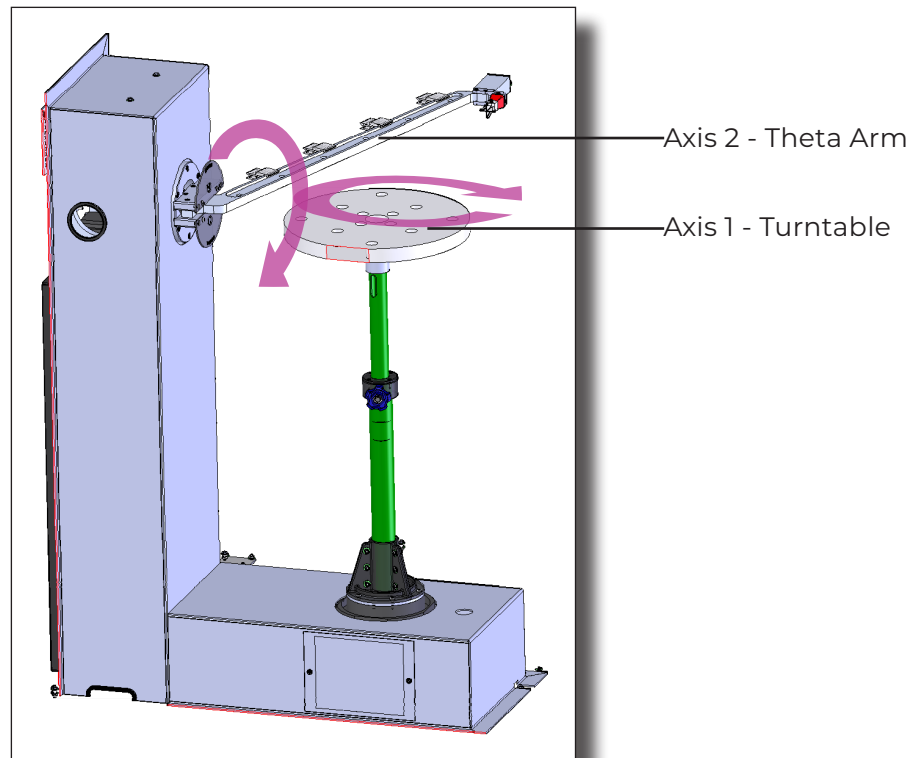



## AMS-5701 Command Set

Both axes rotate both clockwise and counterclockwise. The turntable (Axis 1) has default soft limits at 0° and 360°. The Theta arm (Axis 2) has default soft limits at 0° and 165°.

### Positioner Speeds

AXIS1			AXIS2		
<b>Min Speed</b>	0.25 RPM		<b>Min Speed</b>	0.25 RPM	
<b>Max Speed</b>	12 RPM		<b>Max Speed</b>	12 RPM	
<b>Speed Set</b>	<b>RPM</b>	<b>Deg/s</b>	<b>S</b>	<b>RPM</b>	<b>Deg/s</b>
<b>1</b>	0.25	1.5	<b>1</b>	0.25	1.5
<b>2</b>	0.5	3	<b>2</b>	0.5	3
<b>3</b>	1.0	6	<b>3</b>	0.75	4.5
<b>4</b>	2.0	12	<b>4</b>	1.0	6
<b>5</b>	3.0	18	<b>5</b>	1.25	7.5
<b>6</b>	4.0	24	<b>6</b>	2.0	12
<b>7</b>	6.0	36	<b>7</b>	3.0	18
<b>8</b>	12.0	72	<b>8</b>	6.0	36



The following command set is general and includes commands that may not apply to your specific positioner. Speeds listed in this generic list are representative only.

### General Command Structure

Most of the following commands use this general structure:

[AXIS<n[-m]>:]COMMAND <argument\_n>[,<argument\_m>]

Where:

[ ]

Indicates optional.

< >

Indicates required.

COMMAND

The backwards compatible Model 2090 Multi Device Controller command.

When used by itself, controls the first device in a multi axis system, and, when arguments are required, supports only a single argument.

The command prefix in optional brackets [ ]

Required to access a specific axis or multiple axes at a time.

[AXIS<n[-m]>:]

Selects the desired axis or axes to control.

COMMAND <argument\_n>[,<argument\_m>]

A single index specifies a single axis (e.g. AXIS1 or AXIS2) with a single argument, while a range (e.g. AXIS1-2) specifies a range of axes with a corresponding range of arguments.

Note that some commands only support single axis control.

<argument\_n>

The single argument required for a single axis command.

[,<argument\_m>]

Represents the additional arguments required for an optional multi-axis command (e.g. AXIS1-2:COMMAND 1,2).

## System Commands

Device Identification Query	
<b>Command:</b>	*IDN?
<b>Description:</b>	Identification query. Determines the nature of device located at a given address on the network. The string returned ("ETS-Lindgren Inc., Precision Positioner,<Module Name>,PCA120518 FW N.NN") identifies this device as a Precision Positioner. The <Module Name> parameter is a place holder to identify a specific module. The N.NN parameter is a place holder for the firmware version identification.
<b>Query:</b>	*IDN?
<b>Returns:</b>	ETS-Lindgren Inc.,Precision Positioner,<Module Name>,PCA120518 FW n.nn
<b>Example:</b>	*IDN? ETS-Lindgren Inc.,Precision Positioner,Comm,PCA120518 FW 4.14

Module IP Address	
<b>Command:</b>	MOD:IP <nnn.nnn.nnn.nnn>
<b>Description:</b>	The device default IP address and subnet mask is 192.168.0.100, 255.255.255.0. The default address and subnet mask are assigned to the device by ETS-Lindgren and do not change even if your computer reboots. The IP address can be changed using the MOD:IP command. The port number is 1206.
<b>Query:</b>	MOD:IP?
<b>Returns:</b>	nnn.nnn.nnn.nnn
<b>Example:</b>	MOD:IP 192.168.0.55

Module Name	
<b>Command:</b>	MOD:NAME <Module Name>
<b>Description:</b>	The <Module Name> parameter in the *IDN? query response is a place holder to identify a specific device in a network. If you have more than one device you might want to identify them with different module names. For instance, "EMC LAB1" and "EMC CHAMBER".
<b>Query:</b>	MOD:NAME?
<b>Example:</b>	MOD:NAME EMC LAB1

Module Subnet Mask	
<b>Command:</b>	MOD:NETMASK <nnn.nnn.nnn.nnn>
<b>Description:</b>	The device default IP address and subnet mask is 192.168.0.100, 255.255.255.0. This address and mask are assigned to the device by ETS-Lindgren and does not change even if your computer reboots. The subnet mask can be changed using the MOD:NETMASK command. The new subnet mask will not change even if your computer reboots.
<b>Query:</b>	MOD:NETMASK?
<b>Returns:</b>	nnn.nnn.nnn.nnn
<b>Example:</b>	MOD:NETMASK 255.255.0.0

## Control Commands

Acceleration in Milliseconds	
<b>Command:</b>	A <nnnn>
<b>Description:</b>	Acceleration setting for variable speed devices. The number nnnn represents the time in milliseconds for the positioner to reach max speed. For high inertial loads, a longer acceleration time might be required.
<b>Query:</b>	A?
<b>Returns:</b>	The time in milliseconds for the positioner to reach max speed.
<b>Example:</b>	AXIS1:A 1000

Acceleration in Seconds	
<b>Command:</b>	ACC nn.n
<b>Description:</b>	Acceleration setting for variable speed devices. The number N.N represents the time in seconds for the positioner to reach max speed. For high inertial loads, a longer acceleration time might be required.
<b>Query:</b>	ACC?
<b>Returns:</b>	The time in seconds for the positioner to reach max speed.
<b>Example:</b>	AXIS2:ACC .5

Command Complete Query	
<b>Command:</b>	*OPC?
<b>Description:</b>	Informs if a seek or home command have been completed. Please see home command for an example of how to use the *OPC query.
<b>Query:</b>	*OPC?
<b>Returns:</b>	1 if a seek or home command have been completed, 0 otherwise.
<b>Example:</b>	AXIS3:*OPC?

Current Position	
<b>Command:</b>	CP nn.n
<b>Description:</b>	Changes the current position of the device. When editing limits or the current position setting, the software will not allow the current position to be set outside the software limits, nor can the upper or lower limits be adjusted below or above, respectively, the current position or each other.
<b>Example:</b>	AXIS1:CP 90
<b>Query:</b>	CP?
<b>Returns:</b>	Axis current position The value returned is either in XXX.X or XXX.XX format. Negative values are preceded by a "-" minus sign. Linear positioners return current position in centimeters, turntables return it in degrees..
<b>Example:</b>	AXIS1-3:CP? Response 10.5, -90.0, 70.0

Error Query	
<b>Command:</b>	ERR?
<b>Description:</b>	Queries the axis error register. The error register is cleared on read.
<b>Query:</b>	ERR?
<b>Returns:</b>	An error code (See list at the end of command set.)
<b>Example:</b>	AXIS3:ERR?

Homing Procedure	
<b>Command:</b>	HOME
<b>Description:</b>	<p>The device has a mechanical home sensor. Every time the positioner is turned on, a home procedure must be performed so the current position is known by the firmware. To home the positioner, send the following commands:</p> <pre>HOME *OPC?</pre> <p>Keep querying the positioner by sending the *OPC? until it returns 1.  *OPC? will return 0 if the turntable is still being homed.  *OPC? will return 1 if the home procedure is done.  After *OPC returns 1, send the query HOME? to confirm that the positioner found the mechanical home sensor.  HOME? returns 0 if the home procedure was not successful; result of a faulty sensor.</p>
<b>Query:</b>	HOME?
<b>Returns:</b>	1 if the AXIS1 has been homed, 0 otherwise
<b>Example:</b>	AXIS1:HOME

Lower Limit	
<b>Command:</b>	LL nnn.n
<b>Description:</b>	Sets the lower/counterclockwise limit of the device. The specified value nnn.n must be less than the upper/clockwise limit.
<b>Query:</b>	LL?
<b>Returns:</b>	Lower or counterclockwise limit of the device in degrees.
<b>Example:</b>	AXIS1-2:LL 0,-10

Motion Direction	
<b>Command:</b>	DIR?
<b>Description:</b>	Queries the motion direction for the device.
<b>Query:</b>	DIR?
<b>Returns:</b>	<p>&lt;direction&gt; Value indicating the current motion of the queried device.</p> <pre>+1      Device is moving up/clockwise. 0       Device is stopped. -1      Device is moving down/counterclockwise</pre>
<b>Example:</b>	AXIS1-2:DIR? Response: 0,+1

Move Clockwise	
<b>Command:</b>	CW
<b>Description:</b>	Instructs the positioner to move in the clockwise direction. In non-continuous mode this movement is limited by the clockwise (upper) limit.
<b>Example:</b>	AXIS1-2:CW
Move Counterclockwise	
<b>Command:</b>	CCW
<b>Description:</b>	Instructs the positioner to move in the counterclockwise direction. This movement is limited by the counterclockwise (lower) limit.
<b>Example:</b>	AXIS2:CCW
Scan	
<b>Command:</b>	SCAN
<b>Description:</b>	Instructs the positioner to begin scanning between preset lower and upper limits.
<b>Example:</b>	AXIS1:SCAN
Seek Negative	
<b>Command:</b>	SKN <nnn.n>
<b>Description:</b>	Instructs the device to begin seeking the specified target value in the negative (down/counterclockwise) direction only. This command primarily supports continuous rotation mode. It allows forcing seeking a position from a particular direction. Thus, a SKN from 180.0 to 181.0 will rotate counterclockwise to reach the target value. In non-continuous rotation mode if the target is up/clockwise from the current position, no motion occurs. The target must be located between the current upper/clockwise and lower/counterclockwise limits.
<b>Example:</b>	AXIS1:SKN 30
Seek Position	
<b>Command:</b>	SK nnn.n
<b>Description:</b>	Instructs the device to begin seeking for a target position. In continuous rotation mode, the device will seek the target value by the shortest possible path. Thus, a seek from 350.0 to 10.0 will rotate clockwise, not direction.
<b>Example:</b>	AXIS1-2:SK 90,30
Seek Positive	
<b>Command:</b>	SKP <nnn.n>
<b>Description:</b>	Instructs the device to begin seeking the specified target value in the position (up/clockwise) direction only. This command is provided primarily to support continuous rotation mode. It allows forcing seeking a position from a particular direction. Thus, a SKP from 181.0 to 180.0 will rotate clockwise to reach the target value. In non-continuous rotation mode if the target is down/counterclockwise from the current position, no motion occurs. The target must be located between the current upper/clockwise and lower/counterclockwise limits.
<b>Example:</b>	AXIS2:SKP 90

Seek Relative	
<b>Command:</b>	SKR [+ -]nnn.n
<b>Description:</b>	Instructs the device to begin seeking the specified target value relative to the current position. The specified value is added to the current position to obtain the target position. Thus, a positive value will cause up/clockwise motion and a negative value will cause down/counterclockwise motion.
<b>Example:</b>	AXIS1-2:SKR -10,10

Speed																			
<b>Command:</b>	Sn Where n is a number between 1 and 8. The factory speed settings configuration is: <table border="1"> <thead> <tr> <th>Setting</th> <th>Deg/s</th> </tr> </thead> <tbody> <tr><td>1 -</td><td>0.35</td></tr> <tr><td>2 -</td><td>0.70</td></tr> <tr><td>3 -</td><td>1.05</td></tr> <tr><td>4 -</td><td>1.22</td></tr> <tr><td>5 -</td><td>1.40</td></tr> <tr><td>6 -</td><td>1.56</td></tr> <tr><td>7 -</td><td>1.74</td></tr> <tr><td>8 -</td><td>2.10</td></tr> </tbody> </table>	Setting	Deg/s	1 -	0.35	2 -	0.70	3 -	1.05	4 -	1.22	5 -	1.40	6 -	1.56	7 -	1.74	8 -	2.10
Setting	Deg/s																		
1 -	0.35																		
2 -	0.70																		
3 -	1.05																		
4 -	1.22																		
5 -	1.40																		
6 -	1.56																		
7 -	1.74																		
8 -	2.10																		
<b>Description:</b>	Changes the device speed																		
<b>Query:</b>	S?																		
<b>Returns:</b>	A number between 1 and 8																		
<b>Example:</b>	S3 Set AXIS1 current speed to 1.05 deg/s																		

Speed Preset					
<b>Command:</b>	SS<n> <speed>				
<b>Description:</b>	Assigns a preset speed setting 0-255 to n, where n is a number 1-8. <b>Warning:</b> There can be no white space between the command and the register number. However, there must be white space between the register number and the speed value.				
<b>&lt;speed&gt;</b>	Value from 0-255 representing the desired speed setting for the specified speed selection. A value of 0 represents the minimum available speed of the device. A value of 255 represents the maximum speed of the device. The actual speed of the device is given approximately by the formula: $\text{Actual Speed} = (\text{MaxSpeed} - \text{MinSpeed}) / 255 + \text{MinSpeed}$ For Axis 1, 2, and 3: Min Speed = .18 deg/s Max Speed = 2.45 deg/s				
<b>Query:</b>	SS#?				
<b>Returns:</b>	Value between 0 (minimum) and 255 (maximum) speed.				
<b>Example:</b>	<table border="0"> <tr> <td>SS2 127</td> <td>Set speed 2 to half speed</td> </tr> <tr> <td>SS5 63</td> <td>Set speed 5 to quarter speed</td> </tr> </table>	SS2 127	Set speed 2 to half speed	SS5 63	Set speed 5 to quarter speed
SS2 127	Set speed 2 to half speed				
SS5 63	Set speed 5 to quarter speed				

Stop Motion	
<b>Command:</b>	ST
<b>Description:</b>	Causes device motion to stop.
<b>Example:</b>	AXIS1-2:ST

Trigger Configuration	
<b>Command:</b>	TRIGGER (<ON OFF>, <step size>,<reference>,<pre trigger delay>, <pulse length>,<post trigger delay>,<polarity>)
<b>Description:</b>	Use this command to configure the trigger. Where step size is the angular distance between trigger pulses in degrees, reference position is one of the positions where a trigger should occur (not necessarily a starting position), pre-trigger delay is the time between reaching the target encoder position and producing a trigger pulse, trigger pulse length is the active period of the trigger pulse, post trigger delay is the minimum inactive period after the trigger pulse before another trigger event can occur, and High/Low sets the polarity of the trigger signal. Time unit is milliseconds.
<b>Query:</b>	TRIGGER?
<b>Returns:</b>	Trigger configuration
<b>Example:</b>	TRIGGER (ON,15.00,0.00,0.10,1.00,0.00,LOW)

Upper Limit	
<b>Command:</b>	UL nnn.n
<b>Description:</b>	Sets the upper/clockwise limit of the device. The specified value nnn.n must be greater than the lower/counterclockwise limit.
<b>Query:</b>	UL?
<b>Returns:</b>	Upper or clockwise limit of the device in degrees.
<b>Example:</b>	AXIS2:UL 90

## **Error Codes**

- 1 – Controller board Flash memory malfunction
- 2 – Axis not moving
- 3 – Motor not stopping
- 4 – Motor moving on wrong direction
- 5 – Hardware Limit hit
- 6 – Polarization limit violation
- 7 – Lost communication
- 9 – Encoder failure
- 10 – Trigger failure
- 11 – Motor overheat
- 12 – Relay failure,
- 13 – Position out of bounds
- 14 – Trying to move a locked axis
- 32 – Motor driver fault
- 100-399 – Command syntax error
- 400-499 – Home procedure failure
- 500-599 – Trigger command malformed
- 1000- – Firmware upgrade failure



# NETWORK CONFIGURATION

## Network Factory Configuration

- IP Address.....: 192.168.0.100
- Net Mask.....: 255.255.255.0
- Gateway.....: 192.168.0.1
- Command Port...: 1206

## Changing the Positioner IP Address

In a Local Area Network (LAN), there cannot be more than one device using the same IP address. The IP address of the device will need to be changed if more than one device is in the same (LAN). To change the IP address of an ETS-Lindgren Ethernet device, use its embedded web page.

1. Point your browser to 192.168.0.100 or the address you have previously set your device to.
2. Type the new IP address as highlighted below and click 'SET'.

The screenshot shows a web browser window titled "ETSL Positioner" with the address bar displaying "192.168.0.100". The page content includes the ETS-LINDGREN logo and the title "Positioner". Below the title is a "Command List" section with three main panels: "System", "Position", and "Command". The "System" panel contains fields for "Device" (Positioner), "IP Address" (192.168.0.100), and "Firmware" (6.02 May 28 2021 14:30:47 PCA120518). The "Position" panel has fields for "Axis 1", "Axis 2", and "Axis 3", all set to 0.0. The "Command" panel is expanded to show "Command" as "AXIS1" and includes various control buttons like "GET", "SET", "SEEK", "SK Pos", "SK Neg", "HOME", "ZERO", "CW", "CCW", "CR", "NCR", "SCAN", and "STOP". The "Trigger" panel at the bottom has fields for "State" (OFF), "Step (Deg)" (15.00), "Pre Delay (ms)" (10.00), "Pulse Width (ms)" (1.00), "Post Delay (ms)" (10.00), and "Polarity" (LOW). The "IP Address" field in the "System" panel is highlighted in yellow.

© 2021 by ETS-Lindgren Inc. All rights reserved. (ALP 2/1/21)

A second method for resetting the IP configuration of the device is to connect to the device using any TCP/IP capable terminal application, and sending commands to it. PuTTY is a terminal emulator available for use. PuTTY is a free (MIT licensed) Windows Telnet and SSH client and can be downloaded from <https://www.putty.org/>.

Run PuTTY, and point it to Host 192.168.0.100 Port 1206. Then set Connection type to Raw and click Open.

Ensure the connection is working by typing \*IDN? then pressing the Enter key on the keyboard. The device will respond with an identification string such as the one shown below.

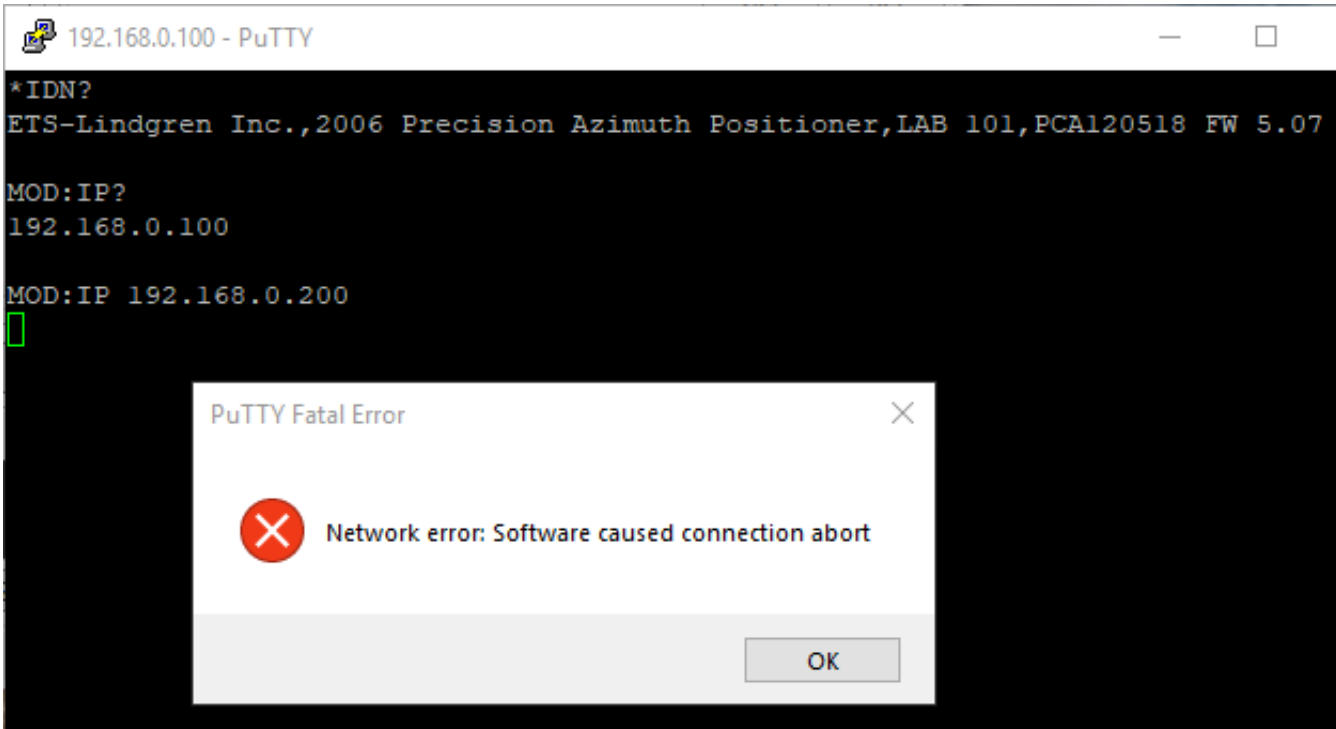

The IP address can be changed using the **MOD:IP** command. To check the current IP address by typing **MOD:IP?**

To change the IP address to 192.168.0.200, type **MOD:IP 192.168.0.200** and press the Enter key on the keyboard. The device will set the new address and reset the connection.

## Reset to Factory Default

To reset configuration, press the reset button for at least 6 seconds. It will reset the IP address back to factory configurations, 192.168.0.100, Mask = 255.255.255.0.

If your positioner does not have a reset button, please follow these instructions to reset the network configuration,

Start with the device powered off for at least 5 seconds

1. Turn the device ON for 5 seconds
2. Turn the device OFF for 5 seconds
3. Repeat steps 1 and 2 four more times for a total of five ON/OFF cycles.

Make sure you wait 5 seconds between power cycles.

This reset procedure only works on devices running on firmware version 5.7 or later

## Computer Network Configuration

Connect to an ETS-Lindgren Ethernet by setting the computer Ethernet interface to the selections shown below.

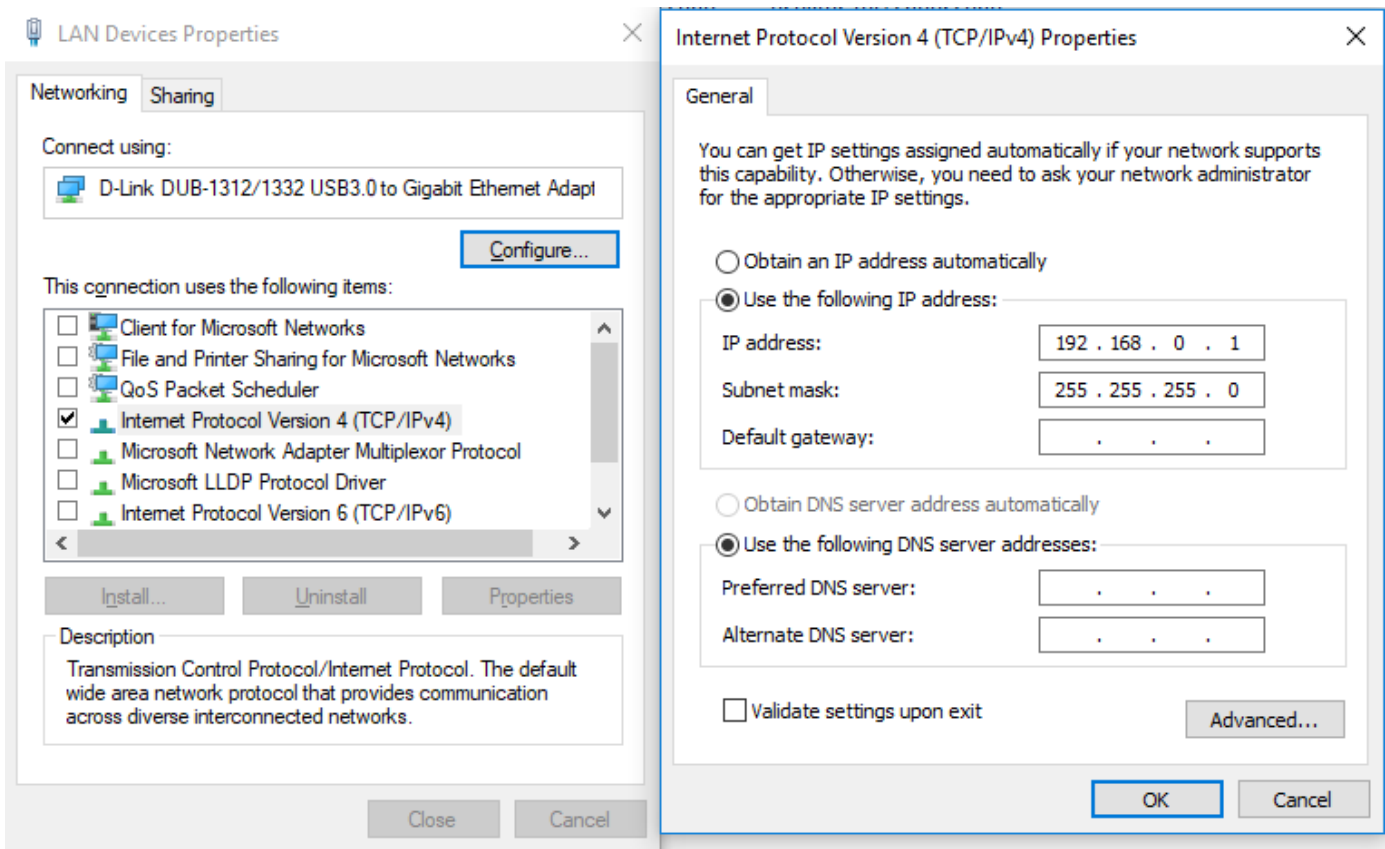

## Background Information

Preparing a computer for connection is relatively simple if you have an Ethernet adapter installed. An Ethernet adapter, also called a network card, network interface card, or network interface controller, provides a physical port for networking mediums such as Ethernet cables. It also communicates with the computer and allows it to access a network device.

Follow these steps on a Windows 10 PC to configure the Ethernet adapter.

1. Verify that the Ethernet adapter is installed:
  - a. Open Device Manager.
  - b. Select "Network adapters."
  - c. Right-click the network adapter.
  - d. Click "Properties." The information in the "Properties" window will indicate whether or not your Ethernet adapter is installed and working.

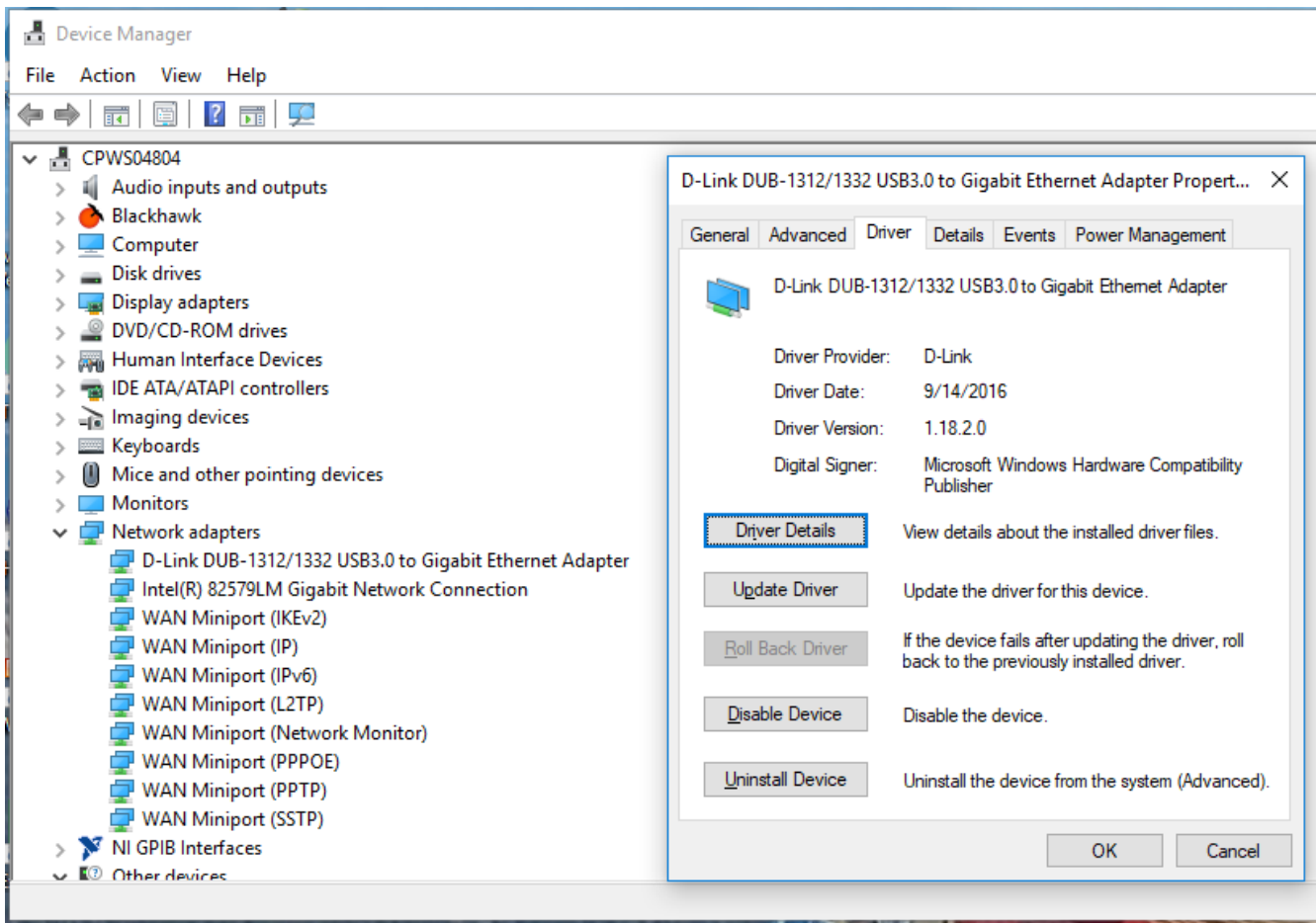

## 2. Configure the Ethernet Adapter

- a. In Windows, click into the Start toolbar.
- b. Type “change Ethernet settings.”
- c. In the search results, click “change Ethernet settings.”
- d. In the Settings window, click “Change adapter options.”

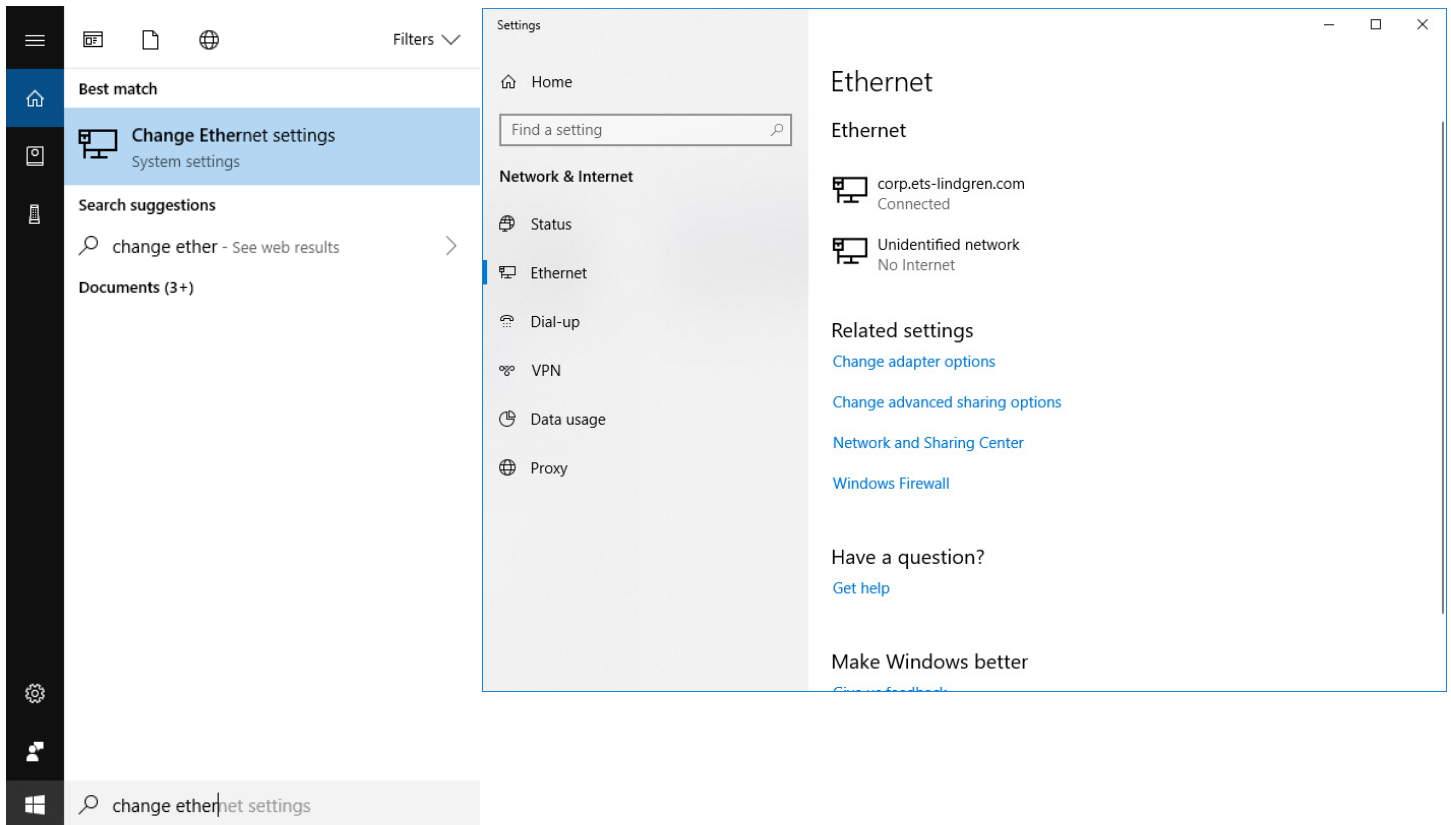

- e. Right click on the Ethernet adapter you intend to configure, and select “Properties.” (Ensure you are logged into an administrator account to change the configuration.)

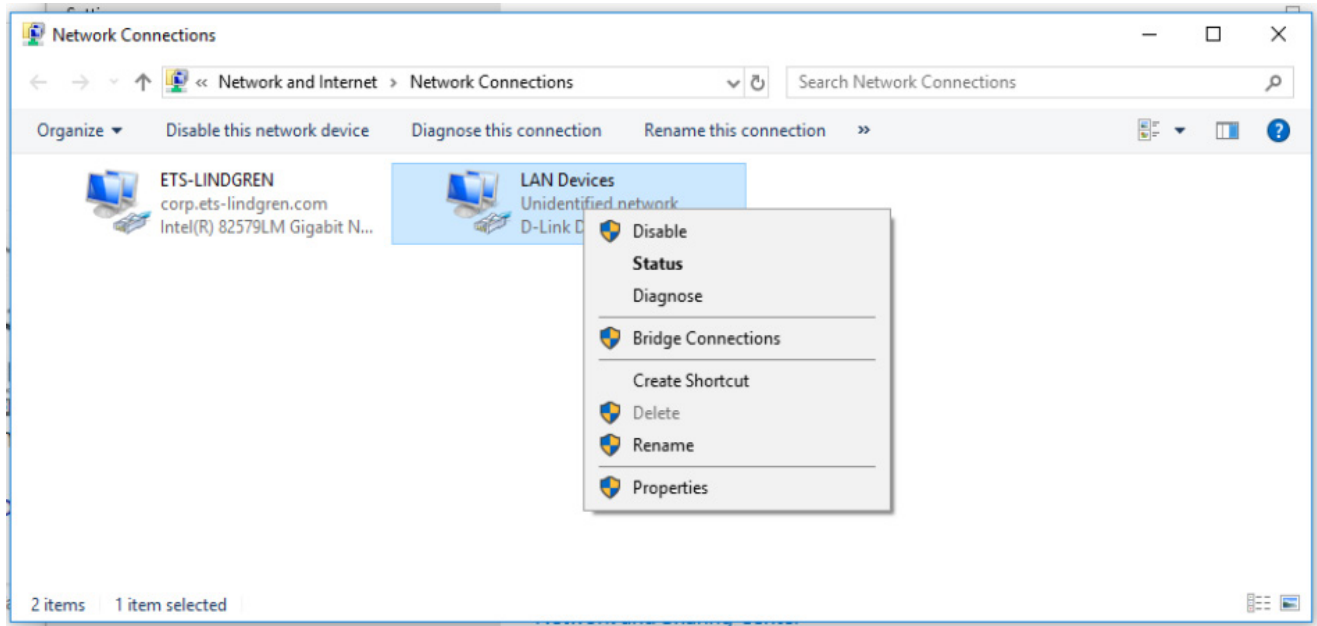

- f. Select "Internet Protocol Version 4 (TCP/IPv4)", then click "Properties". Select "Use the following IP address", then enter the addresses as follows:  
 IP address: 192.168.0.1  
 Subnet mask: 255.255.255.0  
 Default gateway: blank
- g. Select "Use the following DNS server addresses" and leave Preferred and Alternate DNS server fields blank.
- h. Click OK.

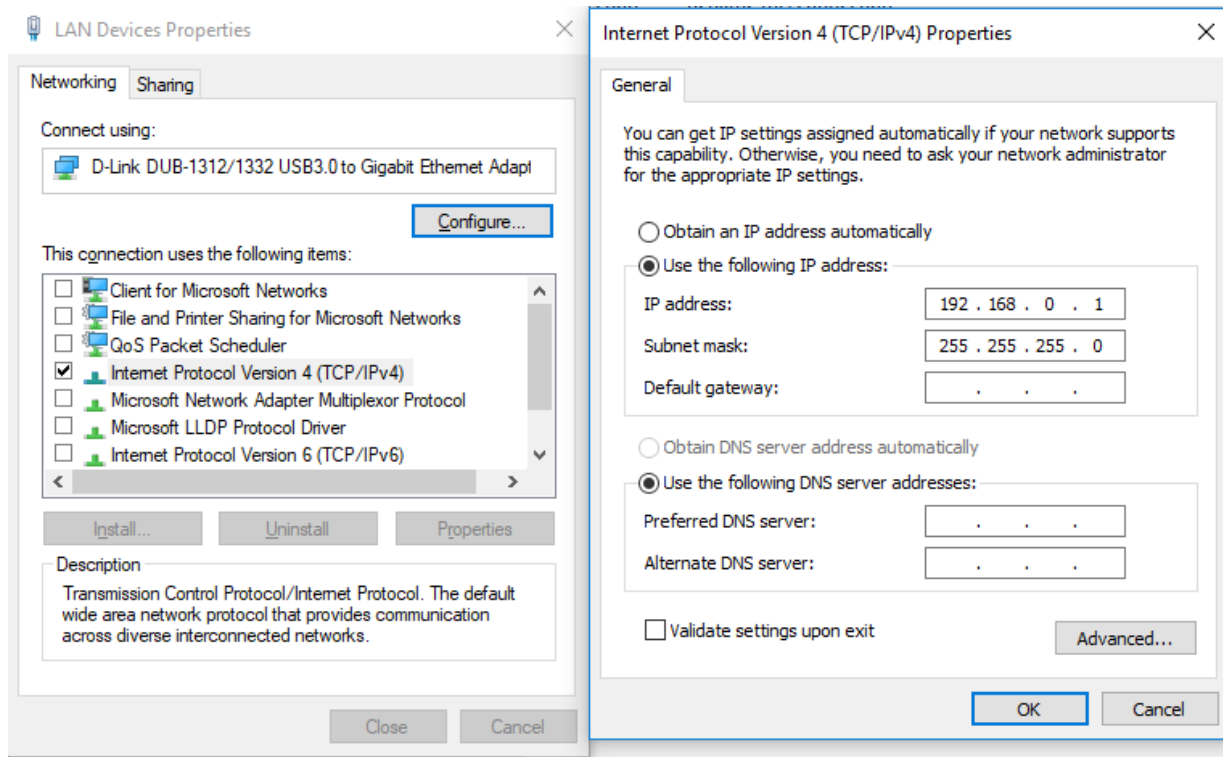

Information about subnet mask can be found online at the following two locations:

<https://www.iplocation.net/subnet-mask>

<https://searchnetworking.techtarget.com/definition/subnet>

## Multiple Devices in a LAN

When using more than one positioner, there is no need for a separate server for each positioner. An Ethernet switch can be used to connect as many devices as necessary to a single computer. Such a configuration requires each device have a unique IP address. If using more than one positioner in a LAN, change the device's IP address. Point your browser to the device (192.168.0.100) and set a new IP address.

Multiple Device LAN

